

PARÇA KODU PART CODE	PARÇA ADI PART NAME	s ÖLÇÜSÜ (KALINLIK) s MEASURE (THICKNESS)	Malzeme Material	Kaplama Coating
TŞ 2473.40 DP	1 NO KABLO UÇ K.A. Ø3.5 =DP=	0.40±0.05	(CuZn30) Pirinç / Brass	_____
TŞ 2473.40 RP	1 NO KABLO UÇ K.A. Ø3.5 =RP=	0.40±0.05	(CuZn30) Pirinç / Brass	_____
TŞ 2473.40 RPK	1 NO KABLO UÇ K.A. Ø3.5 =RPK=	0.40±0.05	(CuZn30) Pirinç / Brass	Kalay / Sn (3-5µ)
TŞ 2473.50 DP	1 NO KABLO UÇ K.A. Ø3.5 =DP=	0.50±0.05	(CuZn30) Pirinç / Brass	_____
TŞ 2473.50 RP	1 NO KABLO UÇ K.A. Ø3.5 =RP=	0.50±0.05	(CuZn30) Pirinç / Brass	_____
TŞ 2473.50 RPK	1 NO KABLO UÇ K.A. Ø3.5 =RPK=	0.50±0.05	(CuZn30) Pirinç / Brass	Kalay / Sn (3-5µ)
TŞ 2473.50 RÇN	1 NO KABLO UÇ K.A. Ø3.5 =RÇN=	0.50±0.05	Nikel kaplı çelik / Nickel plated Steel	Nikel / Ni (>1.5µ)

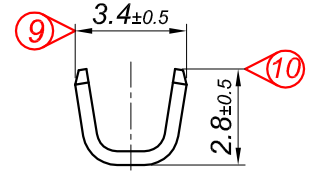

Perspektif
Perspective

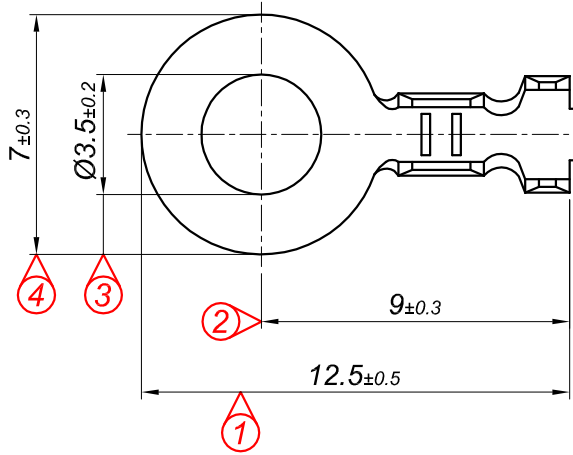
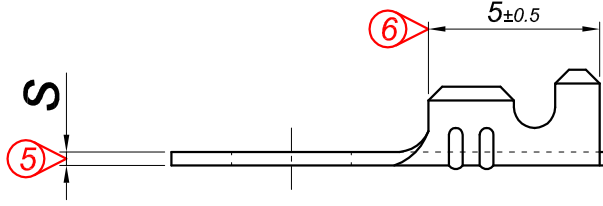
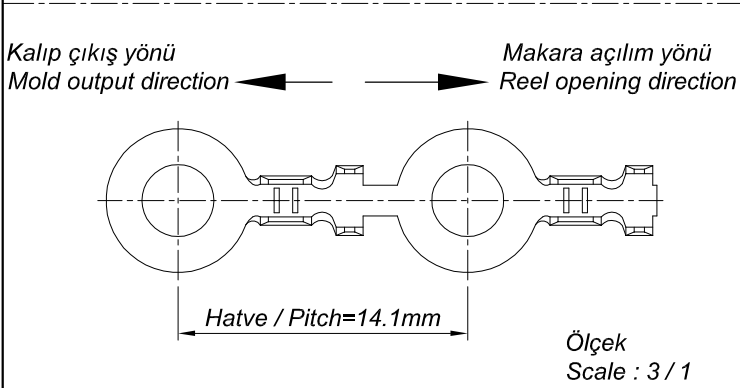

Kablo Kesiti

Wire Section : 0.25 - 0.50 mm²

Resim üzerinden ölçü almayınız
do not measure on drawing

Tarih / Date	18.12.2014	İmza /Signature	Ölçek /Scale		
Çizen / Desing	M.Yağcı		5 / 1		
Onay / Approval	S.Gölcük		No	Değişiklik / Revision	Tarih/Date
	Parça Adı: Part Name	1 NO KABLO UÇ KÜÇÜK AYAK Ø3.5		Parça Kodu: Part Code	TŞ 2473